

Instrument

Click on instrument for diagram

Overhead Cymbals

Snare Drum

Kick Drum

Tom-toms

Hi-hat

Snare, hi-hat and high tom

Shure Mic:

PG81 or SM81

Sound:

Natural; sounds like drummer hears set

Placement:

One mic over center of drum set about 1' over the drummer's head (Position A), or use two spaced or crossed mics for stereo (Positions A or B)

Comments:

Picks up ambience and leakage. To reduce excessive cymbal ring, apply masking tape in radial strips from bell to rim

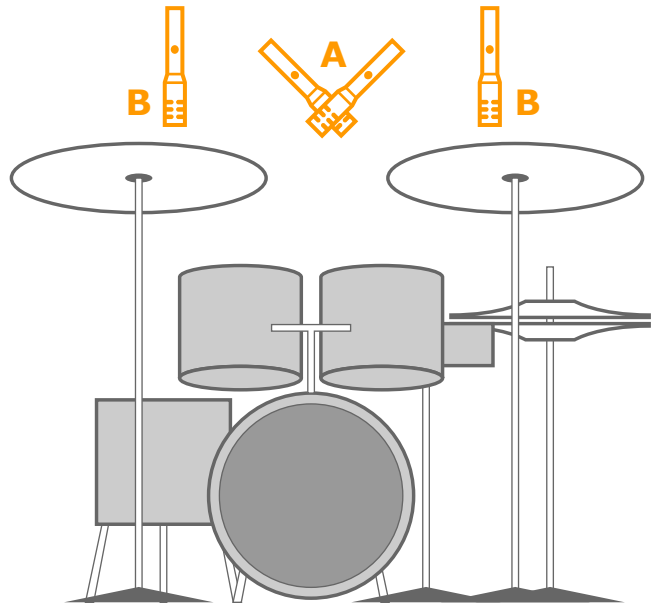

Front View

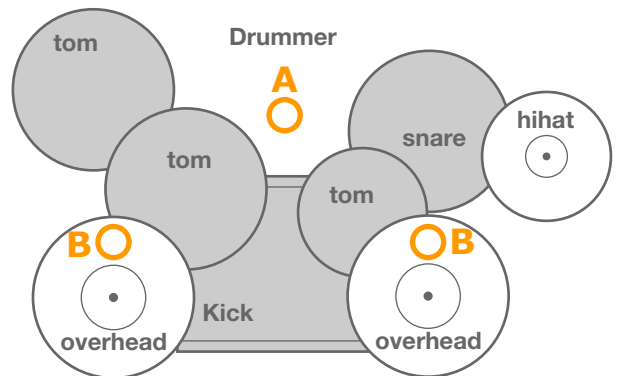

Top View

Instrument

Click on instrument for diagram

Overhead Cymbals

Snare Drum

Kick Drum

Tom-toms

Hi-hat

Snare, hi-hat and high tom

Shure Mic:

PG57 or SM57

Sound:

Full, smooth

Placement:

Just above top head at edge of drum, aiming at top head. Coming in from front of set on boom or miniature microphone mounted directly on drum

Comments:

Tape gauze pad or handkerchief on top head to tighten sound

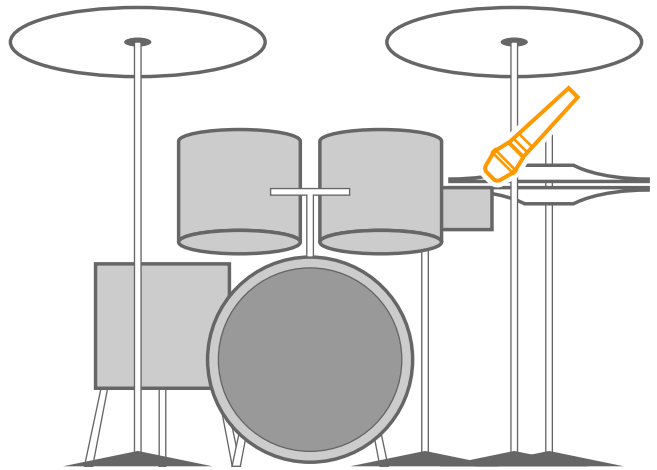

Front View

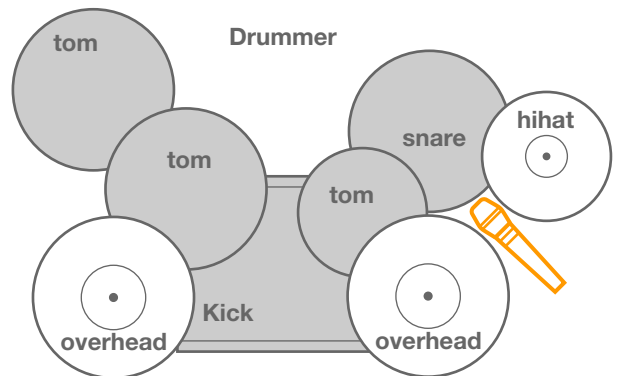

Top View

Instrument

Click on instrument for diagram

Overhead Cymbals

Snare Drum

Kick Drum

Tom-toms

Hi-hat

Snare, hi-hat and high tom

Shure Mic:

PG52 or Beta 52

Sound:

Full, good impact

Placement:

Remove front head if necessary. Mount microphone on boom arm inside drum a few inches away from beater head, about 1/3 of way in from edge of head; or place surface-mounting microphone inside drum on damping material, with microphone element facing beater head

Comments:

Put pillow or blanket on bottom of drum against beater head to tighten beat. Use wooden beater or loosen head for more impact and punch

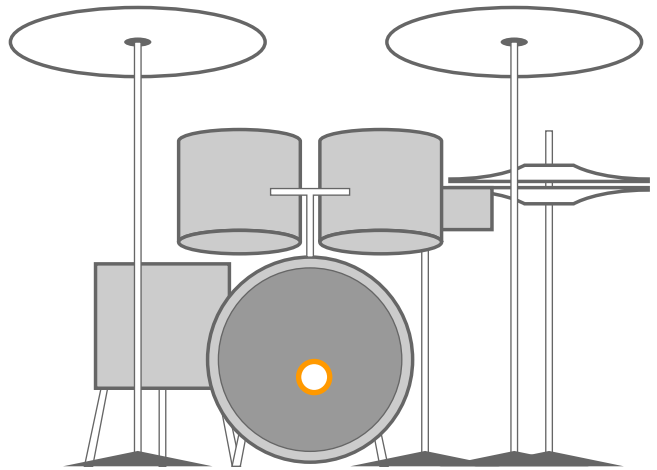

Front View

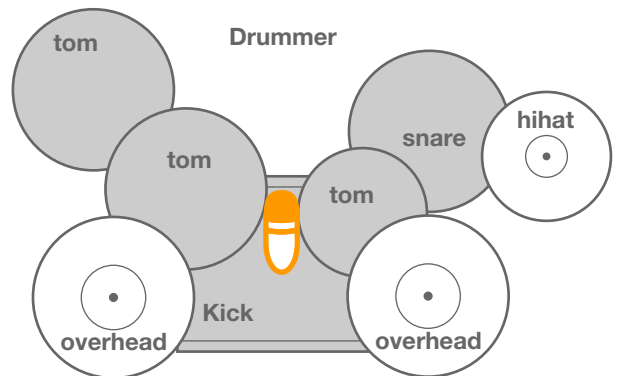

Top View

Instrument

Click on instrument for diagram

Overhead Cymbals

Snare Drum

Kick Drum

Tom-toms

Hi-hat

Snare, hi-hat and high tom

Shure Mic:

PG56, SM57 or Beta 98

Sound:

Full, good impact

Placement:

One microphone between every two tom-toms, close to top heads. (Position E); or one microphone just above each tom-tom rim, aiming at top head (Position F); or one microphone inside each tom-tom with bottom head removed; or miniature microphone mounted directly on drum

Comments:

Inside drum gives best isolation

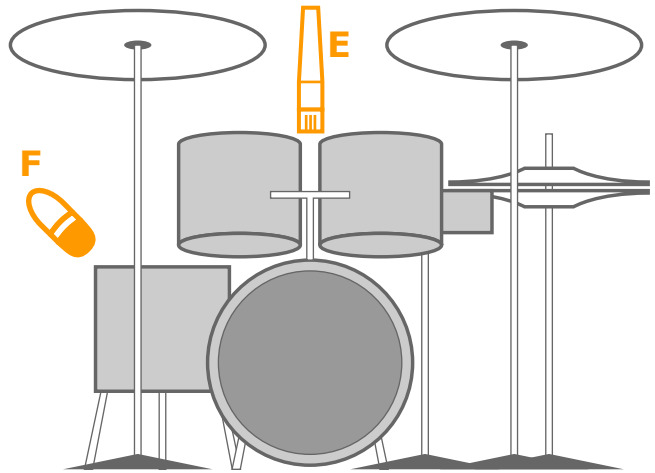

Front View

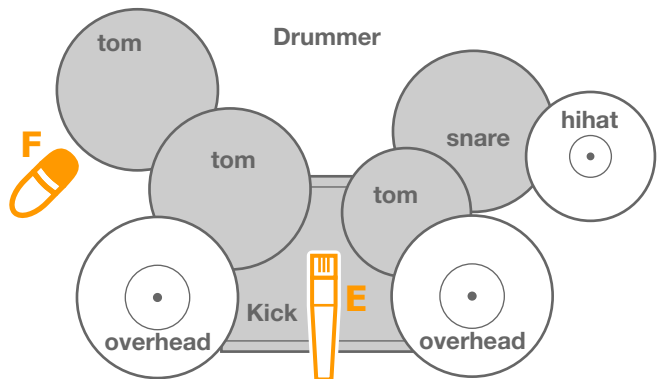

Top View

Instrument

Click on instrument for diagram

Overhead Cymbals

Snare Drum

Kick Drum

Tom-toms

Hi-hat

Snare, hi-hat and high tom

Shure Mic:

PG81 or SM81

Sound:

Natural, bright

Placement:

Aim microphone down toward the cymbals, a few inches over edge away from drummer. Or angle snare drum microphone slightly toward hi-hat to pick up both snare and hi-hat

Comments:

Place microphone or adjust cymbal height so that puff or air from closing hi-hat cymbals misses mic. To reduce hi-hat leakage into snare-drum microphone, use small cymbals vertically placed 1/2" apart

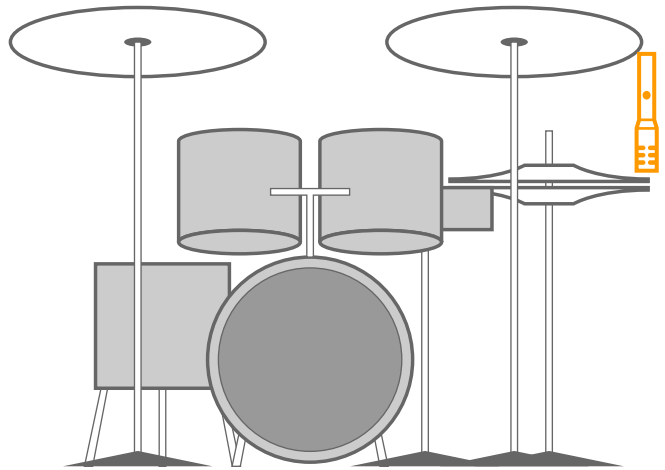

Front View

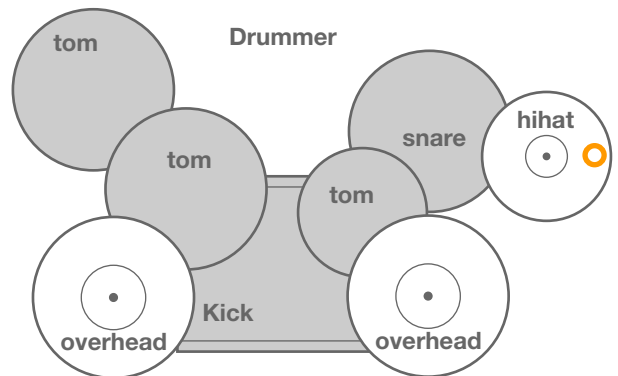

Top View

Instrument

Click on instrument for diagram

Overhead Cymbals

Snare Drum

Kick Drum

Tom-toms

Hi-hat

Snare, hi-hat and high tom

Shure Mic:

PG57 or SM57

Sound:

Natural

Placement:

Place single microphone a few inches from snare drum edge, next to high tom, just above top head of tom. Microphones come in from front of set on a boom

Comments:

Provides good pickup with little leakage

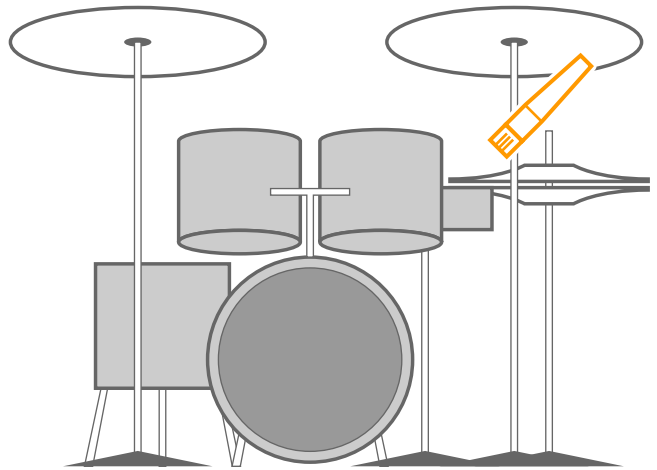

Front View

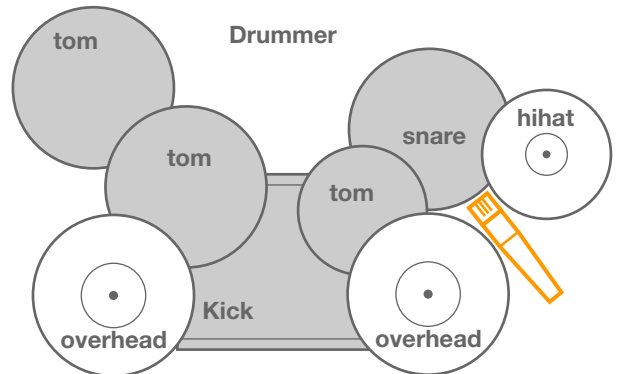

Top View